

Installation of Drive series concrete channels with a hydraulic cross-section LN100-300 along the curb

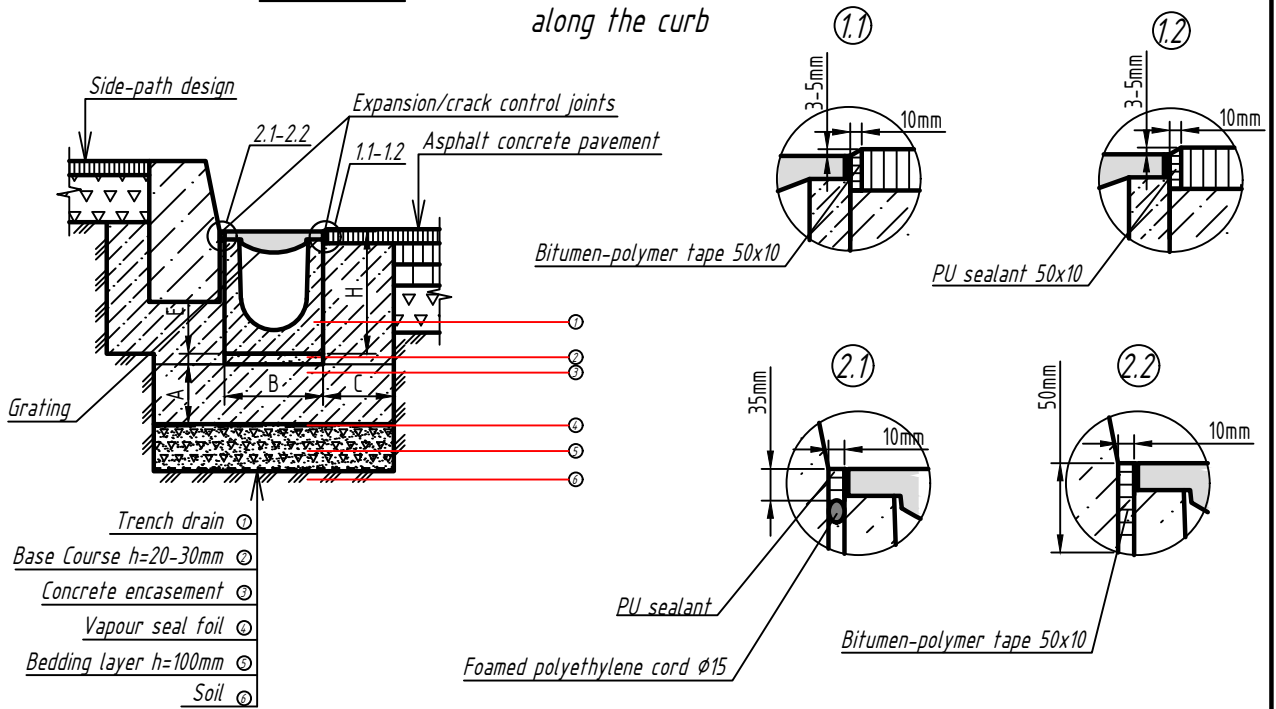

Recommended parameters of the Concrete encasement

Parameter	Load class		
	C250	D400	E600
Concrete encasement depth (A), mm	150	200	250
Concrete encasement width (C), mm	150	200	200
Compressive strength concrete class	C20/25	C25/30	C25/30

Notes

- Parameters of bedding layer, concrete encasements as well as necessity of reinforcement must be selected according to geological conditions of the site.
- If the line length of the trench drains line is more than 10m, expansion joints of the concrete encasement should be designed.
- Heavy load trench drain lines, including traffic transverse motion has to be made of monolithic trench drains CompoMax Monoblock without bolt clamps.
- For compensation of temperature influence and deformation fluctuations of the adjoining pavement, it is recommended to arrange, at a distance of 250-500mm from the edge of the trench drain, longitudinal temperature /expansion joints.
- Applicability of the concrete reinforcement must be approved by E class calculation (rebar type and class).
- Installation diagram is non-regulatory. Check updates on the Standartpark website.

BetoMax Drive LN100-300 Asphalt

BD4-201119

Typical installation scheme of the rain water collection system

Designed	20.11.19	Concrete trench drain Drive series with hydraulic cross section DN100-300	4
Checked			

Installation along the curb



Installation of Drive series concrete channels with a hydraulic cross-section DN100-300 at the stadiums

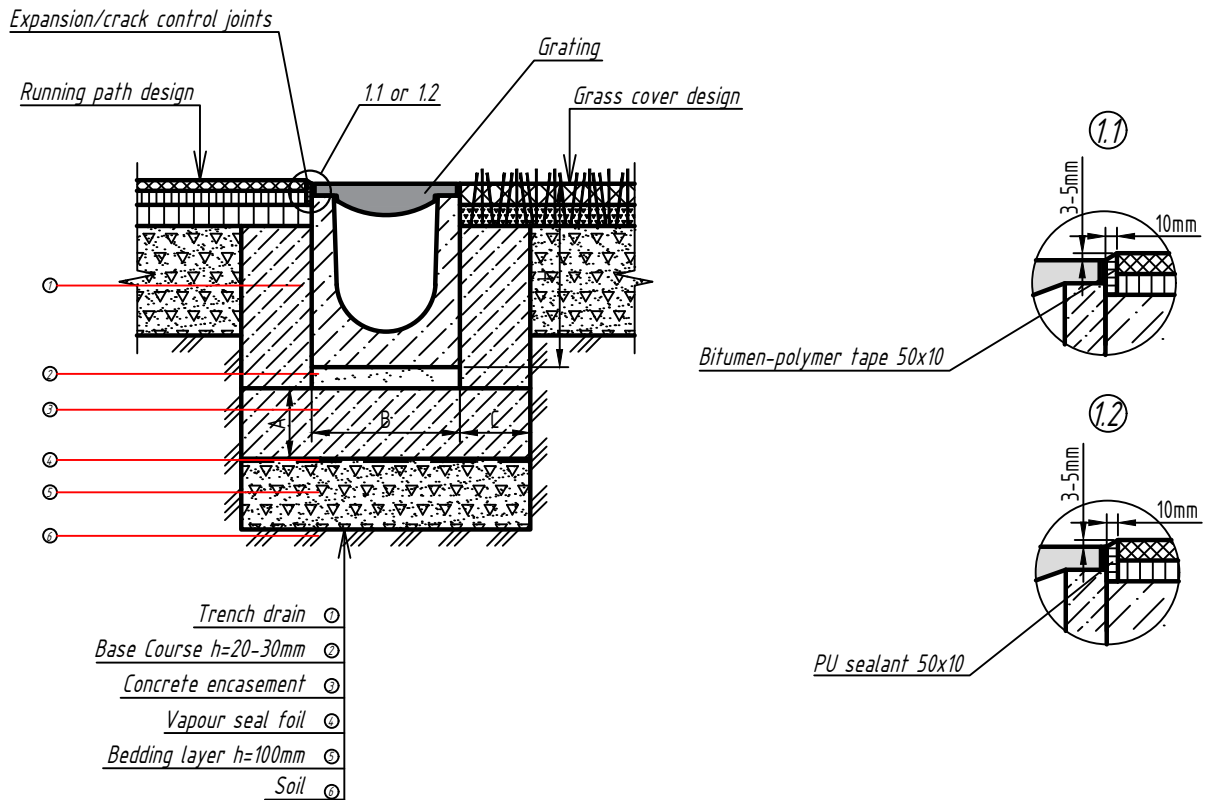

Recommended parameters of the Concrete encasement

Parameter	Load class		
	C250	D400	E600
Concrete encasement depth (A), mm	150	200	250
Concrete encasement width (C), mm	150	200	200
Compressive strength concrete class	C20/25	C25/30	C25/30

Notes

- 1. If the line length of the trench drains line is more than 10m, expansion joints of the concrete encasement should be designed.*
- 2. For compensation of temperature influence and deformation fluctuations of the adjoining pavement, it is recommended to arrange, at a distance of 250-500mm from the edge of the trench drain, longitudinal temperature /expansion joints.*
- 3. Applicability of the concrete reinforcement must be approved by E class calculation (rebar type and class).*
- 4. Installation diagram is non-regulatory. Check updates on the Standartpark website.*

BetoMax Drive DN100-300 Stadiums

BD3-201119

Typical installation scheme of the rain water collection system

<i>Designed</i>		<i>20.11.19</i>	<i>Concrete trench drain Drive series with hydraulic cross section DN100-300</i>			
<i>Checked</i>					<i>3</i>	
			<i>Installation at the stadiums</i>			

Installation of Drive series concrete channels with a hydraulic cross-section LN100-300 into an asphalt concrete pavement

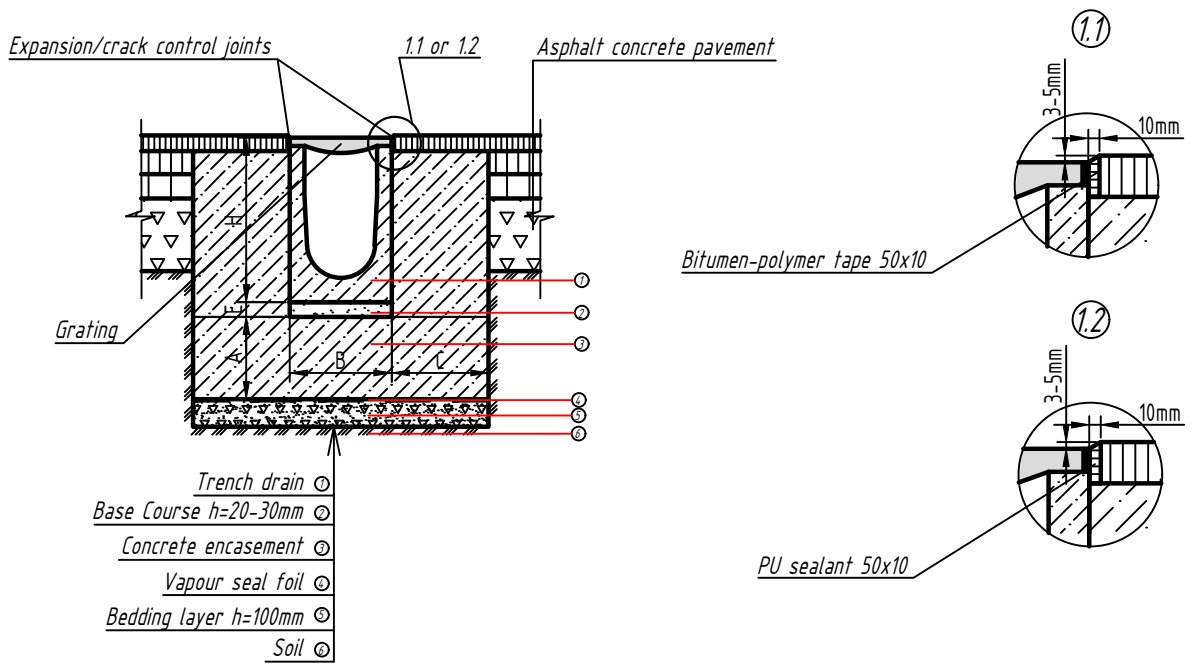

Recommended parameters of the Concrete encasement

Parameter	Load class		
	C250	D400	E600
Concrete encasement depth (A), mm	150	200	250
Concrete encasement width (C), mm	150	200	200
Compressive strength concrete class	C20/25	C25/30	C25/30

Notes

- Parameters of bedding layer, concrete encasements as well as necessity of reinforcement must be selected according to geological conditions of the site.
- If the line length of the trench drains line is more than 10m, expansion joints of the concrete encasement should be designed.
- Heavy load trench drain lines, including traffic transverse motion has to be made of monolithic trench drains CompoMax Monoblock without bolt clamps.
- For compensation of temperature influence and deformation fluctuations of the adjoining pavement, it is recommended to arrange, at a distance of 250-500mm from the edge of the trench drain, longitudinal temperature /expansion joints.
- Applicability of the concrete reinforcement must be approved by E class calculation (rebar type and class).
- Installation diagram is non-regulatory. Check updates on the Standartpark website.

Drive DN100-300 Asphalt

BD1-201119

Typical installation scheme of the rain water collection system

Designed	20.11.19	Concrete trench drain Drive series with hydraulic cross section LN100-300	1
Checked		Asphalt pavement trench drain installation	